

CS 5260BDIP

**Color Standard-Video
CCD Camera**



- **1/2" Interlaced CCD Sensor**
- **NTSC: 768(H) x 494(V) pixel**
PAL: 752(H) x 582(V) pixel
- **Compact and Light Weight**
- **Composite video and YIC output**
- **Application**
 - *Microscopy*
 - *Quality control*
 - *Machine vision*



Technical Data

Type

CS5260BD/P

TV System

NTSC / PAL

Image sensor

1/2" CCD, Corrective Mosaic filter

Active pixel

CS 5260BD ICX418AKL / CS 5260BDP ICX419AKL

768 (H) x 494 (V) NTSC

752 (H) x 582 (V) PAL

Pixel Size

8.4 (H) x 9.8 (V) μm (CS 5260BD), 8.6 (H) x 8.3 (V) μm (CS 5260BDP)

Image Area

CS 5260BD/P

6.5 (H) x 4.85 (V) mm

Scanning lines

525 (NTSC) / 625 (PAL)

Scanning format

2:1 Interlace

Sync system

Internal synchronisation

Scanning frequency

H: 15.625kHz (PAL), 15.734kHz (NTSC) / V: 50Hz (PAL), 59.94Hz (NTSC)

Aspect ratio

4:3

Minimum Illumination

GAIN Max, Gamma=0.45

CS 5260BD/P

4 Lux (F1.4)

Sensitivity setting

AGC (Automatic Gain Control), Manual, Fix

Gamma

Fix 1.0

Video output

1.0 Vp-p / 75 Ohm

White balance

Auto / Manual

Resolution

NTSC 470(H) x 350(V) / PAL 470 (H) x 420 (410 TV lines (V))

S/N

>46 dB(p-p)/rms (GAIN: FIX, Gamma=0)

Electronic Shutter Spec

Shutter speed in 8 steps 1/50, 1/120, 1/250, 1/500, 1/1000, 1/2000, 1/4000, 1/10,000s

CCD integration mode

Field storage (integration)

Lens mount

C-mount

Power supply

DC12V +/-10% approx. 200 mA

Ambient condition

Temperature: 0°C to 40°C, Humidity: 30 to 85%

Dimension

29 (H) x 31 (W) x 70 (D)mm

Weight

approx. 90g

Options

Power supply 0.8A:PS-A05C1-12MT-K, Power supply 1.3:PS-A15D3-12MP-K

Tripod mount: CA-Base-Plate 4xM2

Camera Calibration Software, Interface Power Supply

Windows-Software

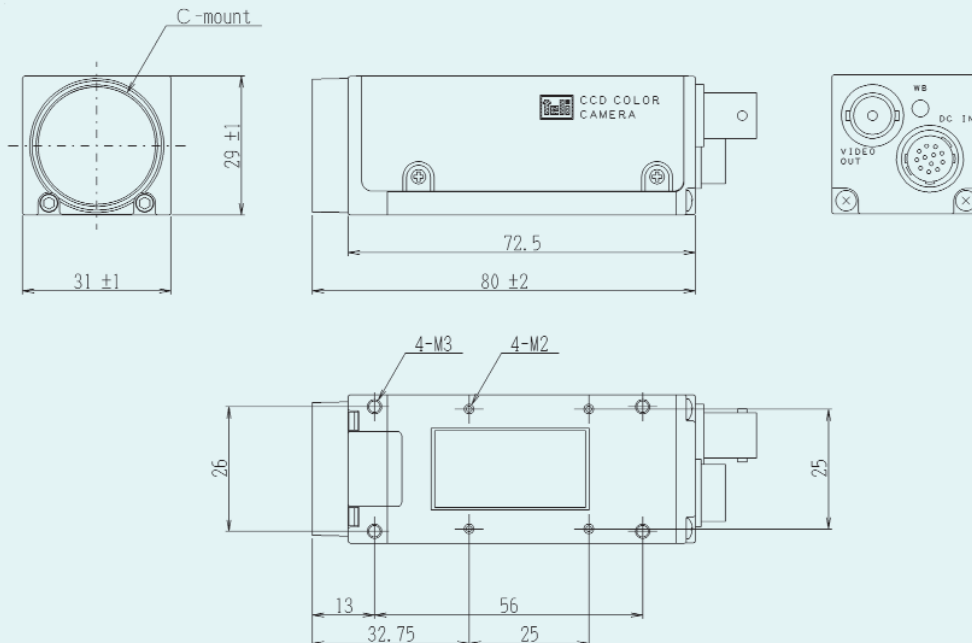

NEW ELECTRONIC TECHNOLOGY Vertriebs-GmbH

Lerchenberg 7 • D 86923 Finning, Germany • Phone: +49(0)88 06 - 92 34-0 • Fax: +49(0)88 06 - 92 34-77

E-mail: info@net-gmbh.com

NET USA, Inc.

3037-45th Street • Highland, IN 46322 • Phone: (219) 934-9042 • Fax: (219) 934-9047

E-mail: info@net-usa-inc.com

www.net-gmbh.com