



General Description

The TM-2016-8 is a miniature, very high-resolution, 2 Megapixel, high-speed monochrome, progressive-scan CCD camera with a 16:9 aspect ratio (like HDTV). The imager resolution is 1920 x 1080 pixels and the frame rate is 8 frames per second. The interline transfer CCD permits full vertical and horizontal resolution of high speed shuttered images. The electronic shutter has speeds up to 1/8,000 sec. and can be reset asynchronously by external pulse control.

The TM-2016-8 has a patent-pending, PULNiX-exclusive, built-in look-up table (LUT). This full dynamic range-control function can be set at externally selectable knee slopes to optimize the CCD's full dynamic range in the normal output signal range. It also provides fast 10-bit to 8-bit conversion pre-processing for effective image feature enhancement. The camera has both analog and digital (RS-644) output for interfacing with frame grabbers.

All camera control functions are externally controlled via a user-friendly RS-232C graphical interface provided by PULNiX.

Applications for the TM-2016-8, which has a 16:9 aspect ratio and wide field of view, include machine vision, medical imaging, intelligent transportation systems, high-definition graphics, gauging, character recognition, documents archiving, surveillance, and aerial imaging.

Asynchronous Reset

The TM-2016-8's asynchronous reset is flexible and accepts external horizontal drive (HD) for phase locking. When the VINIT pulse is applied, the scanning is reset and a new frame will be generated. There are two asynchronously-reset shutter speed control modes:

1. External VINIT with pulse width. The duration between pulse edges controls the shutter speed externally.
2. Internal shutter speed control. The speed control varies from 1/60 to 1/8,000 sec. The video signal and FDV starts with internal V reset timing related to shutter speed.

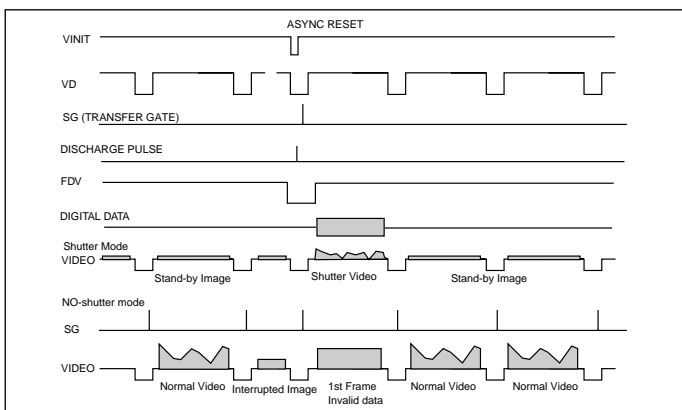

Product Summary

- High resolution, 1920(H) x 1080(V) at 8 frames per second
- 1" progressive scan, interline transfer CCD imager for good dynamic range.
- Miniature 44x44x64 mm housing with high-rel connector
- Digital RS-644 (LVDS) output and analog output
- Maximum dynamic range control with PULNiX-exclusive, patent-pending built-in look-up table (Gamma, knee, user parameters)
- Full frame integration, two-row binning (1920x540) pixels at 16 frames per second.
- Full-frame shutter to 1/8,000 sec.
- Asynchronous reset, no-delay shutter and read-out-inhibit control for multiple camera applications
- RS-232 external control
- Color version (RGB Bayer CFA) is available (TMC-2016)

Electronic Shutter

The TM-2016-8 has a substrate drain-type shutter mechanism which provides a superb picture at various speeds without smearing. A built-in manual shutter speed control selects the electronic shutter rate of 1/30 (non-async mode only), 1/60, 1/125, 1/250, 1/500, 1/1,000, 1/2,000, 1/4,000, 1/8,000 second.

The CCD discharges when discharge pulses are applied via internal shutter control. With a negative pulse to VINIT, the camera resets and purges the CCD charge momentarily. Then it starts integrating for the period of preset shutter control time by either an external pulse width or internal shutter control.

Progressive scanning permits a full 1080 lines of vertical resolution, as compared to a conventional CCD camera which captures only half the vertical lines per shutter.

Integration

The CCD imager of the TM-2016-8 can be exposed for longer than the normal scan timing of 1/8 sec. This integration feature provides extra sensitivity for dark-environment applications. The progressive scan imager permits a full frame of resolution in non-interlace format. Integration is achieved either by: (1) direct control of INTEG signal pin 11 or (2) Pulse Width control, up to 3 sec. by VINIT on pin 6 (pin 20 on 31-pin digital output).

AccuPIXEL™ is a registered trademark of PULNiX America, Inc.

TM-2016-8 Progressive Scan 2K x 1K Shutter Camera

Dynamic Range Control

Typical interline transfer CCDs have fixed noise levels based on dark current (thermal or KT noise), pattern noise, and operating clock speed. Typically for a 2K x 1K CCD operating at 20MHz pixel clock, the noise level is around 40 electrons. The maximum capacity of the CCD charges is limited by the well capacity at saturation. The range is limited by the structure and the pixel size.

The TM-2016-8 uses a 1" CCD with 7.4 μm x 7.4 μm pixel and two-phase vertical shift register structure. The well capacity is 50,000 electrons. The theoretical dynamic range is 50,000:40 = 1250:1 (62 dB).

A typical CCD camera does not use the full dynamic range due to the nominal gain and the output specification such as RS-170. The typical CCD camera has its gain set at 16 to 22 dB and the RS-170 video level is 714 mV. Using 20 dB gain for the calculation, CCD output is limited to 714/10 = 71.4 mV. Since the CCD's saturation voltage is 400 mV to 500 mV, the system therefore uses less than 1/5 of the available dynamic range.

Machine vision and outdoor applications cannot afford to miss image information behind the saturation, which is why the dynamic range adaptation is critical.

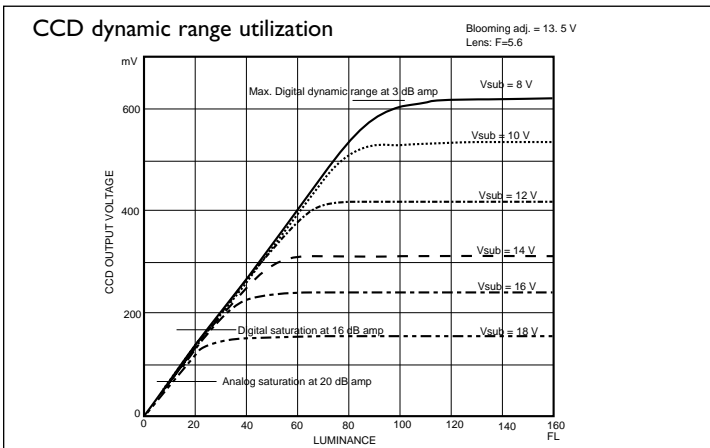

Programmable LUT and Knee Control (patent pending)

The TM-2016-8 has a built-in LUT (look-up table) for dynamic range control and preprocessing for feature enhancements. At a specific gain setting, the offset (minimum

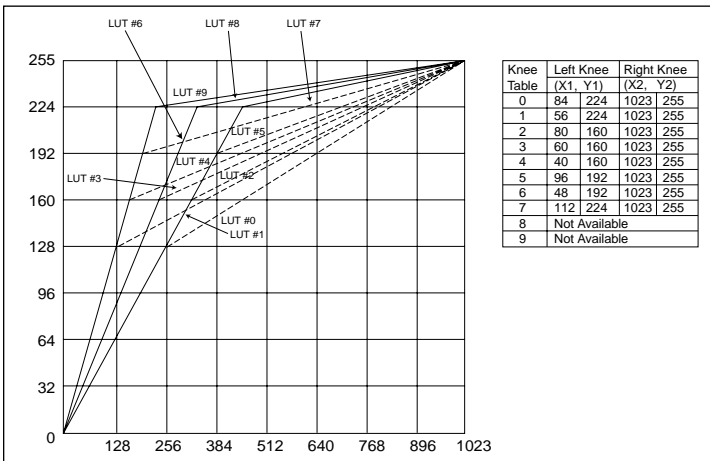

level... dark point) and A/D reference top voltage (maximum level... saturation point) are set to 10-bit A/D input so that the full dynamic range of the CCD is utilized at 10-bit references as the input and the LUT output is converted into 8-bit to adjust the gamma correction.

The 10-bit input is segmented into two or more regions by the knee point settings as variable gamma selection.

LUT selections: (10 sets of standard knee values)

- 1 Variable knee curve
- 2 Direct input LUT

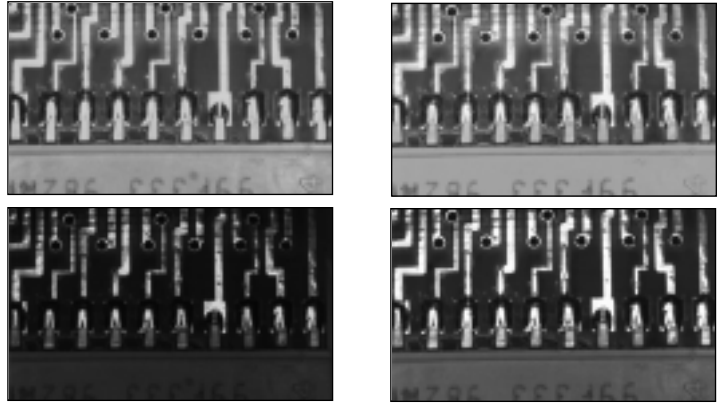

Linear image: When PCB surface is visible, metal trace is saturated. If the metal surface appears, then the plastic surface is too dark.

Knee-controlled image: The upper is visible, metal trace is saturated. If the metal surface appears, then the plastic surface is too dark.

Scan Mode

Full Progressive Scan

The normal scanning mode for the TM-2016-8 is 1920 x 1080 pixels. The standard speed with single-channel output is 8 frame/sec at the pixel clock of 20.0 MHz. Unlike an interlace scan camera, the TM-2016-8 reads every line from top to bottom, resulting in all lines being obtained per captured image frame with electronic shutter.

Two-Row Binning

This is a standard feature in the TM-2016-8. The camera scans two rows together and outputs 1920 (H) x 540 (V) pixels at 16 frames per second. Two-row binning is typically implemented to increase the frame rate.

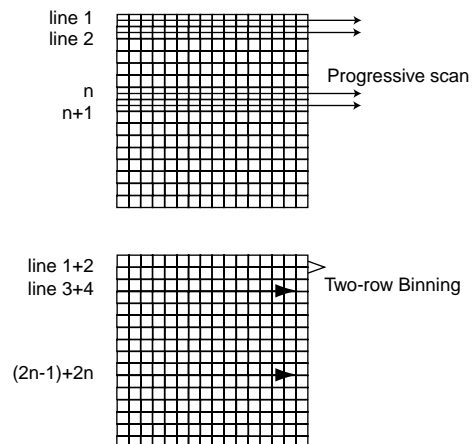

TM-2016-8 Progressive Scan 2K x 1K Shutter Camera

External Sync

The TM-2016-8 accepts an external sync. of standard HD and VD at TTL level for general locking to a system sync. and clock. External sync. is only available for 8-frame mode. The frequency requirement is as follows:

$$f_{HD} = 9.09 \text{ KHz} \pm 5\%$$

$$f_{VD} = 8.0 \text{ Hz} \pm 5\%$$

(Internal Master clock = 40.0 MHz,
Pixel clock = 20.0 MHz)

Please contact PULNiX for TM-2016-8 timing charts.

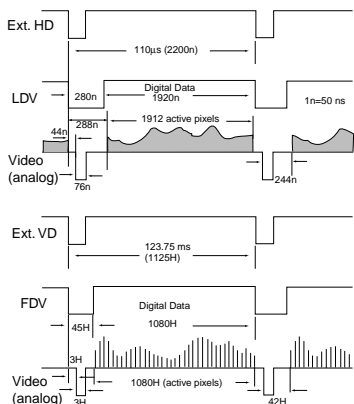

No-delay shutter and Read-out-inhibit

For multiple camera applications such as 2D or 3D measurement and multi-angle inspection, simultaneous image capturing at an exact shutter timing for all cameras is critical requirement. TM-2016-8's **async pulse width control mode** provides no-delay shutter as standard. Regardless the internal pulse timing, it discharges at VINIT leading edge and transfers charges at trailing edge of the pulse. Even though each camera runs with slightly different H and data clock timing, the image capturing is exactly simultaneous.

TM-2016-8 has also read-out-inhibit (ROI) to control the vertical clock to start (**Async Shutter #9**). When ROI is low, V-clock is stopped and the transferred charges remain in the vertical shift registers, which works as if CCD memory. When ROI is high, it clocks out the CCD data. This helps a single frame grabber to process multiple images in pipeline processing (sequential process).

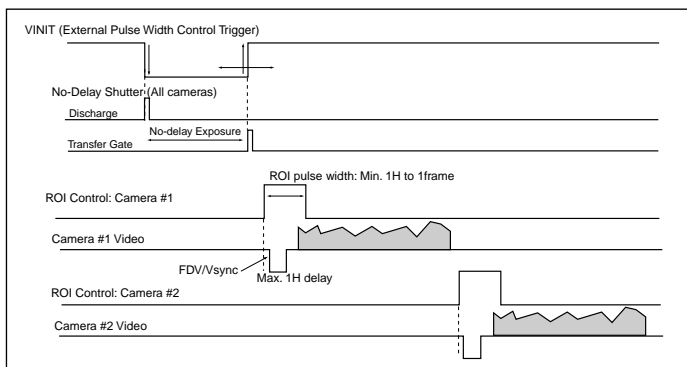

Mode Switches

Various modes can be implemented with the rear panel-mode selection switch and Up/Down switch as well as RS-232

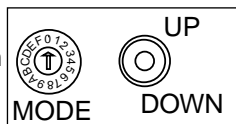

external control. When RS-232 is connected, the command over-writes the rear panel switch settings.

Mode Switch	Up/Down Switch	Functions
0 Switch Disabled	Switch Disabled	None
1 Set Gain	Up / Down	Change gain
2 Set Vtop (A/D)	Up / Down	Change A/D ref. top
3 Set Vbottom (A/D)	Up / Down	Change A/D ref bottom
4 Gain Selection #1	Up: 9dB, Down: 12dB	Lower gain selection
5 Gain Selection #2	Up: 18dB, Down: 22dB	Higher gain selection
6 Linear LUT	Up	Back to linear table
7 Knee Selection	Up / Down (Scroll)	Scroll 10 different LUTs
8 Async Reset Mode	Up: Normal, Dwn: Async	Async and normal shutter
9 Factory Default Recall	Up / Down: Recall	Factory setting
A Power up Setting	Up: Recall, Dwn: Save	Power up page setting
B User Page Storage#1	Up: Recall, Dwn: Save	User page storage setting
C User Page Storage#2	Up: Recall, Dwn: Save	User page storage setting
D Direct Shutter Control	Up / Down	Shutter speed increment by 1H
E Scan Format2	Up: Optional, Dwn: Binning	Two-row binning selection
F Scan Format1	Up: Normal, Dwn: Optional	Custom option scanning

Connector and Pin Configurations

Digital Output Connector

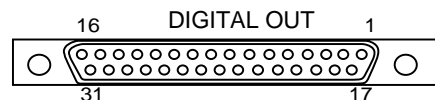

31-Pin connector (MQ-213-031-113-0000)					
Pin#	Description	I/O	Pin#	Description	I/O
1	CLK+	Out	17	CLK-	Out
2	LDV+	Out	18	LDV-	Out
3	FDV+	Out	19	FDV-	Out
4	GND		20	VINIT	In
5	EXT HD (TTL)	In	21	[INTEG (TTL)	In
	[EXT CLK+	In		EXT VD (TTL)	In
6	INTEG	In	22	N/C	
	[HD+	In		[HD-	In
7	N/C		23	GND	
	[Vinit+/(VD+)	In		[Vinit-/(VD-)	In
8	D0+	Out	24	D0-	Out
9	D1+	Out	25	D1-	Out
10	D2+	Out	26	D2-	Out
11	D3+	Out	27	D3-	Out
12	D4+	Out	28	D4-	Out
13	D5+	Out	29	D5-	Out
14	D6+	Out	30	D6-	Out
15	D7+	Out	31	D7-	Out
16	GND				

Note: CLK: data clock, LDV: Line data valid, FDV: Frame data valid, INTEG: Integration control, EXT CLK: external pixel clock, []: Differential input option

12-Pin Connector	
1 GND (power)	7 VD in
2 +12V	8 N/C
3 GND (analog)	9 HD in
4 Video out	10 RXD(RS232)
5 GND (digital)	11 Int. cont
6 VINIT in	12 TXD(RS232)

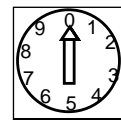
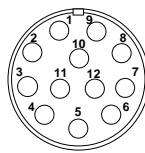

Shutter Control Switch		
	Manual	Async
0	no shutter	no shutter
1	1/20	1/8,000
2	1/60	1/4,000
3	1/125	1/2,000
4	1/250	1/1,000
5	1/500	1/500
6	1/1,000	1/25000
7	1/2,000	1/125
8	1/4,000	1/60
9	1/8,000	Ext. pulse width control

TM-2016-8 Progressive Scan High-Resolution Shutter Camera

SPECIFICATIONS

Imager	1" progressive scan interline transfer CCD
Active Area	14.2mm x 8.0mm
Active Pixels	1920 (H) x 1080 (V), 16:9 aspect ratio
Cell size	7.4 μm x 7.4 μm
Display Modes (Active Pixels)	1920 (H) x 1080 (V) @ 8Hz (normal scan) 1920 (H) x 540 (V) @ 16Hz (two-row binning)
Sync	Internal/external auto switching HD/VD, 4.0 Vp-p impedance 4.7K Ω VD=8 Hz \pm 5%, non-interlace, HD=9.09 kHz \pm 5%
Data clock output	20.0 MHz
Resolution	Digital: 1920 (H) x 1080 (V), Analog: over 1200 TV lines (H) x 800 TV lines (V)
S/N ratio	50dB min.
Min. illumination	2.0 lux, f=1.4 without IR cut filter (no shutter) Sensitivity: 13 $\mu\text{V}/\text{e}^-$
Video output	Analog: 1.0 Vp-p composite video, 75 Ω Digital output: 8-bit RS-644

AGC	OFF
Gamma	Programmable LUT(1.0 std.)
Lens mount	C-mount (use 1" format lenses)
Power req.	12V DC, 440 mA (current measured at 25 $^{\circ}$)
Operating temp.	-10 $^{\circ}$ C to 45 $^{\circ}$ C*
Vibration	7Grms (10 Hz to 2000 Hz) Random
Shock	70G
Size (W x H x L)	44mm x 44mm x 64mm (1.73" x 1.73" x 2.50")
Weight	136 grams, 4.8 oz
Functional options	adjustable back-focus front end

Optional accessories	(must be ordered separately)
I/O	30DG-02 digital output cable CS-232E serial communication kit
Power cable	12P-02S (Optional)
Power supply	PD-12UUP series (includes power connector)

* Image quality will degrade with increasing temperature.

Graphical User Interface

A user-friendly graphical user interface (GUI) of TM-2016-8 camera control is provided in the CS-232E kit. This interface allows users to control the following functions of the TM-2016-8 camera:

- Shutter control for manual, async. and pulse width control
- Gain control
- A/D reference voltages control for Vtop and Vbottom
- Save settings
- Load settings
- Report settings
- LUT setting and graphic display
- Scanning mode selection and Option selections

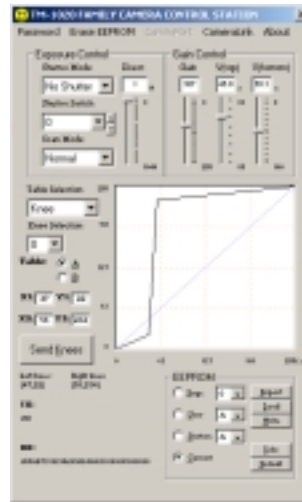

Camera parameters can be uploaded from the PC to the camera. Once these parameters are stored in EEPROMs, an instantaneous change from one setting to another can be done with a delay of a few frames in between.

Serial Communication Kit

The serial communication kit CS-232E consists of serial cable RS-232B-12, a software disk, and a quick-start guide. The RS-232B-12 cable has a 12-pin connector on the camera end, and a 9-pin d-sub connector (RS-232) and a 12-pin connector (power and sync signals) on the other end.

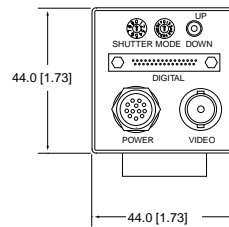
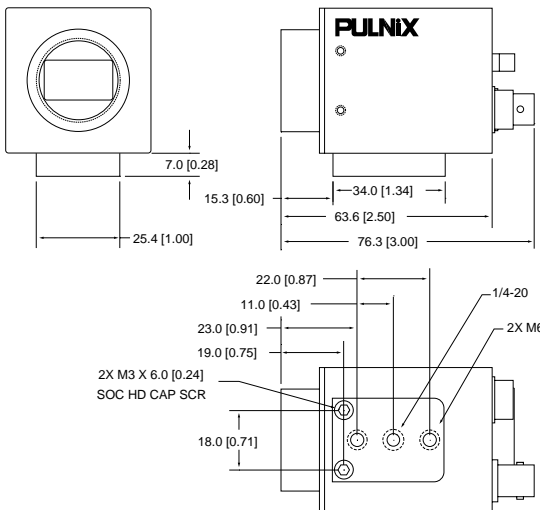

PULNiX

Innovation at work!

PULNiX America, Inc. Tel: 408-747-0300
1330 Orleans Drive Tel: 800-445-5444
Sunnyvale, CA 94089 Fax: 408-747-0660