

TM-250/260 High-Resolution Miniature CCD Camera

PULNiX

Imaging Products



General Description

The TM-250/260 camera offers a high-resolution interline transfer 1/2" CCD imager in a very tiny package. The camera's extremely short length allows it to fit into very shallow spaces, even when using normal-size connectors. In contrast, most other cameras leave very little extra space when used with specific C-mount optics and standard connectors.

The TM-250/260 front end measures 44mm square, and the imager center is located at the same distance from either side.

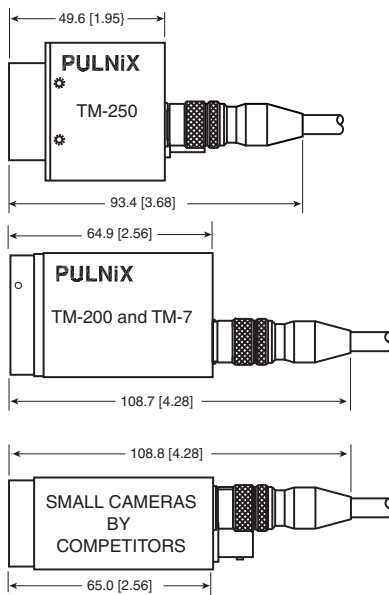

This means that the camera can be mounted either right side up or sideways without changing the optical axis. All circuit boards are securely integrated inside the camera to assure the most robust design for the most demanding applications.

The camera is available in two formats: EIA (TM-250) and CCIR (TM-260). It has many standard and optional features at a very affordable price. In a departure

from the common practice of using a standard CCD and its chipset, the TM-250/260 uses a PULNiX-proprietary timing generator chip. This allows the TM-250/260 camera to be used as a base model for OEM applications that require highly specialized, custom cameras with non-standard options.

The most commonly needed adjustments—manual gain control, automatic gain control, gamma, and field/frame selection—can be easily accessed on the camera's rear panel.

Electronic shuttering is another standard feature with continuous or async, reset-restart modes. Fourteen shutter speeds, ranging from 1/60 sec. to 1/29,000 sec., can be selected externally using the switch on the rear panel.

These cameras fit easily, both physically and functionally, into all types of machine vision, automated inspection, and related applications. Other uses include remotely piloted vehicles, miniature inspection devices, surveillance, microscopes and medical equipment.

Product Summary

- High-resolution 1/2" format CCD
TM-250: 768 H x 494 V (EIA)
TM-260: 752 H x 582 V (CCIR)
- Versatile machine vision camera
- Super mini size (Length: 62.3mm; 22% shorter than the TM-200 and the TM-7CN)
- Advanced Hyper-HAD™* interline transfer CCD
- Shutter from 1/60 to 1/29,000 (continuous and async)
- Externally adjustable MGC/ AGC, gamma and field/frame select
- External sync, Async reset, Reset-restart, Variable asynchronous shutter
- Custom and OEM models available

TM-250/260 Spectral Response

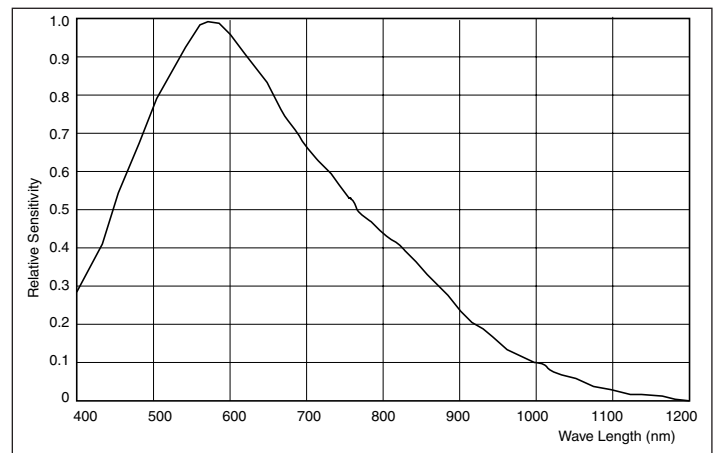

*Hyper-HAD is a registered trademark of Sony Corporation

TM-250/260 High-Resolution Miniature CCD Camera

Operating Modes

The TM-250/260 operates in the following modes that can be selected by the DIP switch on the rear panel of the camera.

- ① Standard Interlace Mode
 - Field integration Mode
 - Frame integration Mode
- ② External Sync Mode
- ③ Noninterlace Mode
- ④ Cyclic (continuous) Shutter Mode
- ⑤ Asynchronous Reset and Asynchronous Shutter
- ⑥ Reset-Restart Mode
 - Frame integration Mode
 - Field integration Mode
- ⑦ Reset-Restart Mode with Electronic Shutter
 - Frame integration Mode
 - Field integration Mode
- ⑧ Integration Mode (Strobe application)

① Standard Interlace Mode

Field Mode and Frame Mode

The field and frame integration mode is selectable. The frame integration is used to separate all CCD pixels and the exposure of Odd and Even fields generate the full frame image shown in the figure below.

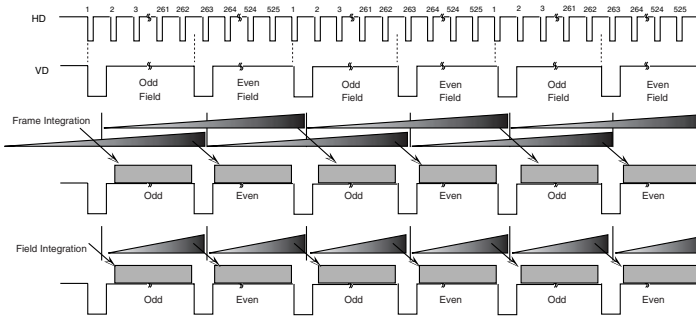

Field Mode Binning

The field integration is done by combining two pixel rows (binning) together, each pair alternating as interlace scan is generated. Row 1 is binned with row 2, and row 3 is binned with row 4. In Field 2, row 2 is binned with row 3, row 4 with row 5, and so on. Field mode is very effective in shutter mode because the pixel sensitivity is doubled for field integration (1/60 sec) and equals frame mode (one row at 1/30 sec). Because Shutter mode is only one field output per shutter and darker than normal image, two-row binning is effective. This mode also reduces interlace moire when a sharp horizontal pattern is observed. For higher pixel definition such as gauging and sub-pixel interpolation, Frame mode operation is recommended.

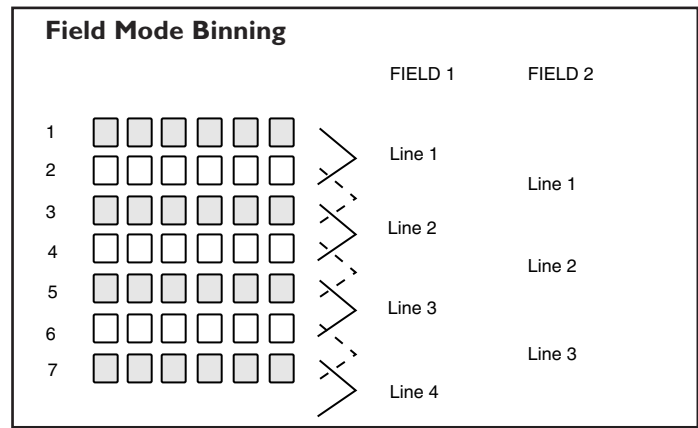

② External Sync Mode

The TM-250/260 accepts standard RS-170 external sync, which is defined as horizontal sync (HD) and vertical sync (VD). The phase-locked loop jitter is designed to be the minimum ($< 5\text{ns}$) in this category using the latest PLL chip. The wide capture range enables the camera to operate at an extended temperature range (optional) of -35°C to 65°C . HD and VD input is TTL level and the high impedance is $100\text{K}\Omega$ or 75Ω (optional).

③ Non-Interlace Operation Mode

With external sync of non-interlace, the camera operates at non-interlace scanning. External VD must be generated at integers of $262\text{H} \pm 8\text{H}$. (Standard interlace is 262.5H)

④ Cyclic (Continuous) Shutter Mode

With back-plate shutter control, the TM-250/260 operates at the internally predefined shutter speeds. Each field output is exposed for the same period. The shutter control varies the substrate discharge timing. The duration between the shutter pulse and transfer gate timing (1IH^* from VD edge) decides the exposure time. ($*16\text{H}$ for CCIR) The following three cyclic shutter modes are available:

- High-Speed Cyclic Shutter mode
- Trigger Position Reset/Restart Shutter mode
- Trigger Width Reset/Restart Shutter mode

Contact PULNiX for timing charts of various cyclic shutter modes.

TM-250/260 High-Resolution CCD Camera

Operating Modes (Continued)

⑤ Asynchronous Reset and Asynchronous Shutter

By supplying VINIT pulse on pin #6, the camera can be reset asynchronously. In this mode, when VINIT is kept high, it continuously discharges the CCD and outputs the field video signal upon the negative going edge. The output stays continuous during VINIT low. The first field output is always Odd.

The following four asynchronous shutter modes are available:

- Strobe Asynchronous Shutter Mode
- Pre-Reset Asynchronous Shutter Mode
- Post-Reset Asynchronous Shutter Mode
- Pulse Width Asynchronous Shutter Mode

Please contact PULnix for timing charts of various asynchronous shutter modes.

⑥ Reset-Restart Mode

Rather than using VINIT as async reset, the camera can be reset using EXT.VD. In this mode, the camera needs multiple VD pulses to output valid images depending on whether it is set to Field or Frame mode. Usually, the first field (field mode) or first frame (frame mode) is garbage because of previous signal residuals prior to reset. A frame grabber has to know which frame or field to capture. External HD must be applied for this operation.

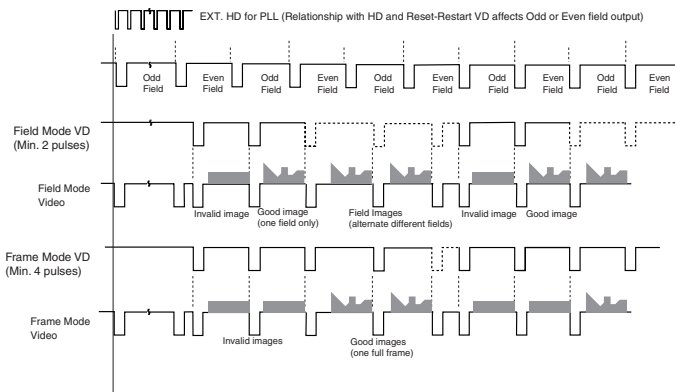

⑦ Reset-Restart with Electronic Shutter

The shutter speed or exposure can be controlled with external pulse width control or external pulse position control in this mode. In combination with Reset-Restart pulse (EXT.VD), the camera can be externally controlled for the image-capture timing as well as the exposure time.

This is an excellent application for capturing multiple images (two fields of images) of indexing objects under various lighting or brightness conditions. When Frame mode is selected, the full vertical resolution is achieved even using an electronic shutter by taking two fields of shutter images.

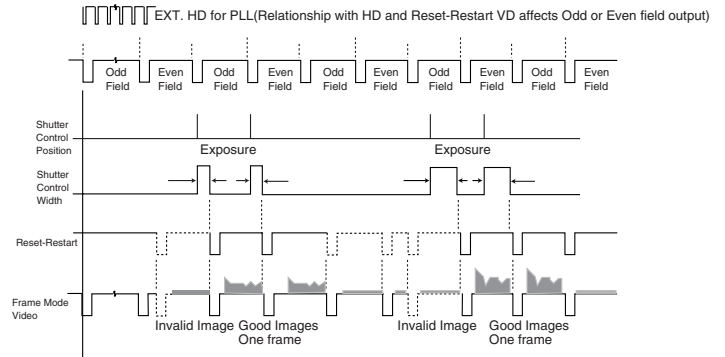

⑧ Integration Mode

When integration control is low, the CCD imager keeps integrating and when the signal returns to high, it enables the charge transfer for video output. This mode integrates longer than one field and with strobe light application, it can capture randomly strobed images during the integration. It also increases the exposure time to enhance low light viewing.

12P-02S Interface Cable (optional)			
Pin#	Lead Color	Function	Pin Configuration
1	Gray	GND	
2	Yellow	+12V DC	
3	Red coax shield	GND	
4	Red coax	Video	
5	Orange coax shield	GND	
6	Orange coax	VINIT/TRIG*	
7	Black coax	VD Input	
8	White coax shield	GND	
9	White coax	HD Input	
10	Brown	N/C	
11	Blue	N/C	
12	Black coax shield	GND	
* VINIT is active low. TRIG is active high.			

TM-250/260 High-Resolution Miniature CCD Camera

Rear Panel Switches

The following tables indicate the various TM-250/260 modes of operation and the DIP switch settings on the rear panel of the camera.

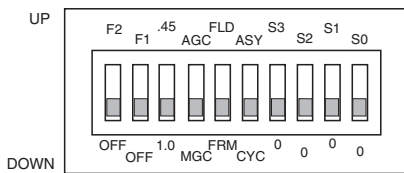

Function Control

1. F2: Up = Function 2 ON
Down = Function 2 OFF
2. F1: Up = Function 1 ON
Down = Function 1 OFF
3. Gamma: Up = 0.45
Down = 1.0
4. AGC/MGC: Up = AGC (Automatic Gain Control)
Down = MGC (Manual Gain Control)

When MGC is selected, the camera gain can be adjusted using the potentiometer on the back plate.
5. FLD/FRM: Up = FLD (Field Mode)
Down = FRM (Frame Mode)
6. ASY/CYC: Up = Asynchronous Mode
Down = Cyclic Mode Shutter
7. S3 to S0: See Shutter Speed Control Switches on the reverse side of this page.

Trigger Width Reset/Restart Shutter Mode

F1	ASY	S3	S2	S1	S0	Trigger Polarity
OFF	CYC	0	0	0	0	Positive
Up	Down	Up	Up	Up	Up	Positive

F2: not applicable.

Trigger Position Reset/Restart Shutter Mode

F1	ASY	S3	S2	S1	S0	Trigger Polarity
OFF	CYC	0	0	0	0	Positive
Up	Down	Up	Up	Up	Down	Positive

F2: not applicable.

Strobe Asynchronous Shutter Mode

F1	ASY	S3	S2	S1	S0	Trigger Polarity
OFF	CYC	0	0	0	0	Negative
Down	Up	Down	Down	Down	Down	Negative

F2 Up: Both odd and even field pictures are obtained in Frame mode.

Double Pulse Integration Mode

F1	ASY	S3	S2	S1	S0	Trigger Polarity
OFF	CYC	0	0	0	0	Negative
Up	Up	Up	Up	Up	Down	Negative

F2 Up: SYNC signal is continuous.
F2 Down: SYNC signal is available in one field right after VINIT.

Pulse Width Asynchronous Shutter Mode

F1	ASY	S3	S2	S1	S0	Trigger Polarity
OFF	CYC	0	0	0	0	Negative
Down	Up	Up	Up	Up	Up	Negative

F2 Up: SYNC signal is continuous.
F2 Down: SYNC signal is available in the two fields (Frame mode) and in one field (Field mode) right after VINIT.

Pulse Width Integration Mode

F1	ASY	S3	S2	S1	S0	Trigger Polarity
OFF	CYC	0	0	0	0	Negative
Up	Up	Up	Up	Up	Up	Negative

F2 Up: SYNC signal is continuous.
F2 Down: SYNC signal is available in the two fields (Frame mode) and in one field (Field mode) right after VINIT.

TM-250/260 High-Resolution Miniature CCD Camera

Rear Panel Switches (Continued)

Shutter Speed Control in Post-Reset Asynchronous Shutter Mode						
Switch Position						Shutter Speed (Sec.)
F1 OFF	ASY CYC	S3 0	S2 0	S1 0	S0 0	
Down	Up	Down	Down	Down	Up	1/60
Down	Up	Down	Down	Up	Down	1/120
Down	Up	Down	Down	Up	Up	1/250
Down	Up	Down	Up	Down	Down	1/500
Down	Up	Down	Up	Down	Up	1/1,000
Down	Up	Down	Up	Up	Down	1/1,600
Down	Up	Down	Up	Up	Up	1/1,800
Down	Up	Up	Down	Down	Down	1/2,100
Down	Up	Up	Down	Down	Up	1/2,400
Down	Up	Up	Down	Up	Down	1/2,800
Down	Up	Up	Down	Up	Up	1/3,500
Down	Up	Up	Up	Down	Down	1/4,400
Down	Up	Up	Up	Down	Up	1/6,200
Down	Up	Up	Up	Up	Down	1/10,200

F2 Up: SYNC signal is continuous.
F2 Down: SYNC signal is available in one field right after VINIT.

Shutter Speed Control in Pre-Reset Asynchronous Shutter Mode						
Switch Position						Shutter Speed (Sec.)
F1 OFF	ASY CYC	S3 0	S2 0	S1 0	S0 0	
Up	Up	Down	Down	Down	Up	1/29,100
Up	Up	Down	Down	Up	Down	1/10,200
Up	Up	Down	Down	Up	Up	1/6,200
Up	Up	Down	Up	Down	Down	1/4,400
Up	Up	Down	Up	Down	Up	1/3,500
Up	Up	Down	Up	Up	Down	1/2,800
Up	Up	Down	Up	Up	Up	1/2,400
Up	Up	Up	Down	Down	Down	1/2,100
Up	Up	Up	Down	Down	Up	1/1,800
Up	Up	Up	Down	Up	Down	1/1,600
Up	Up	Up	Down	Up	Up	1/1,500

F2 Up: SYNC signal is continuous.
F2 Down: SYNC signal is available in one field right after VINIT.

Shutter Speed Control in High-Speed Cyclic Shutter Mode						
Switch Position						Shutter Speed (Sec.)
F1 OFF	ASY CYC	S3 0	S2 0	S1 0	S0 0	
Down	Down	Down	Down	Down	Down	1/30 (no shutter)
Down	Down	Down	Down	Down	Up	1/60
Down	Down	Down	Down	Up	Down	1/100
Down	Down	Down	Down	Up	Up	1/120
Down	Down	Down	Up	Down	Down	1/250
Down	Down	Down	Up	Down	Up	1/500
Down	Down	Down	Up	Up	Down	1/1,000
Down	Down	Down	Up	Up	Up	1/1,500
Down	Down	Up	Down	Down	Down	1/2,100
Down	Down	Up	Down	Down	Up	1/2,800
Down	Down	Up	Down	Up	Down	1/3,500
Down	Down	Up	Down	Up	Up	1/4,400
Down	Down	Up	Up	Down	Down	1/6,200
Down	Down	Up	Up	Down	Up	1/10,200
Down	Down	Up	Up	Up	Down	1/29,100

F2: not applicable.

TM-250/260 High-Resolution Miniature CCD Camera

Product Specifications

Model	TM-250 (EIA)	TM-260 (CCIR)
Imager	1/2" Interline transfer CCD, HAD type	
Pixel	768 (H) x 494 (V)	752 (H) x 582 (V)
Cell size	8.4 μm x 9.8 μm	8.6 μm x 8.3 μm
Scanning	525 lines	625 lines
Sync	Internal/External auto switch $fH=15.734$ KHz $\pm 5\%$, $fV=59.94$ Hz $\pm 5\%$	
Pixel clock	14.318 MHz	14.188 MHz
TV resolution	570 (H) x 350 (V)	560 (H) x 420 (V)
S/N ratio	50 dB min. AGC off	
Min. illumination	0.5 lux (F=1.4)	
Video output	1.0 Vp-p composite video, 75 Ω	
AGC	ON/OFF (back panel selectable)	
Gamma	1 or 0.45 (back panel selectable)	
Lens mount	C-mount	
Power requirements	190 mA, 11-15V	
Operating temp.	-10° C to +50° C	
Vibration & shock	Vibration: 7Grms/10-2000 Hz; Shock: 70G	
Size (W x H x L)	44.0mm x 44.0mm x 62.3mm 1.73" x 1.73" x 2.45"	
Weight	120g (4.2 oz.)	
Power cable	12P-02S (optional)	
Power supply	K25-12V, PD-12P, PD-12U series	PD-12UE series
Functional options	Internal IR Cut Filter; Optical Filter Removal; Glassless CCD Imager; DC Coupled; Low impedance termination; NIR CCD; SONY pinouts; Adjustable backfocus front end	
Accessories	See current price list	

OEM Custom Cameras

Various versions of the OEM cameras are possible based on the TM-250 base model. Some examples include:

- Near IR-sensitive CCD (as a model)
- 2/3" CCD
- 1/3" CCD
- Flying lead output (straight from back or right angle from side)
- Special timing and reset version
- Higher frame rate
- CS-mount front end

Please contact PULNiX if your application needs cameras with any of the above options.

Cables

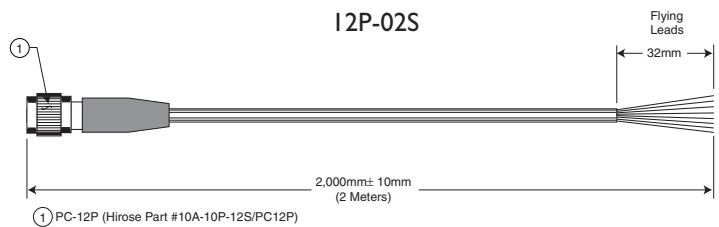

Physical Dimensions

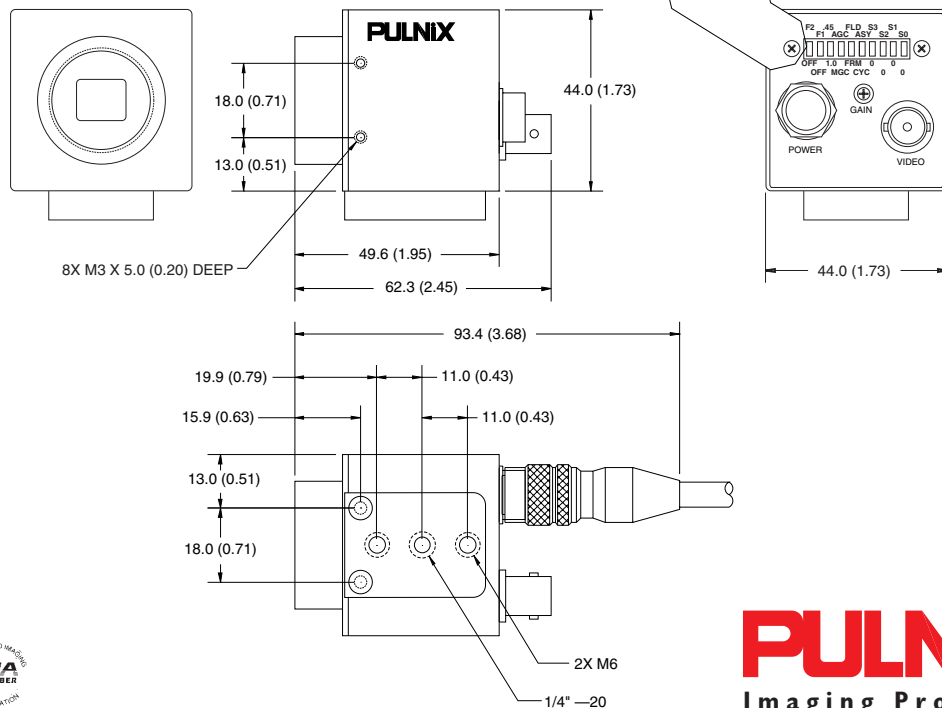

PULNiX
Imaging Products

71-0044 Rev.A

TM-250/260



Japan
PULNiX America, Inc.
1-11-14 Hongo Bunkyo-ku, Tokyo 113-0033
Tel: 81-3-5805-2455
Fax: 81-3-5805-8082
Kyoto Office:
Tel: 81-75-594-6688
Fax: 81-75-581-7118

Australia
PULNiX America, Inc.
Unit 16, #35 Garden Road
Clayton, Victoria 3168
Tel: 613-9546-0222
Fax: 613-9562-4892

United Kingdom
PULNiX Europe, Ltd.
PULNiX House,
Aviary Court, Wade Road
Basingstoke, Hampshire
RG24 8PE
Tel: 44(0)1256-475555
Fax: 44(0)1256-466268

Germany
PULNiX Deutschland,
GmbH.
Siemensstrasse 12
D-63755 Alzenau
Germany
Tel: 49(0)6023-9625-0
Fax: 49(0)6023-9625-11

PULNiX America, Inc. Tel: 408-747-0300
1330 Orleans Drive Tel: 800-445-5444
Sunnyvale, CA 94089 Fax: 408-747-0660

www.pulnix.com
email: imaging@pulnix.com