

# PULNiX TM-6710CL

Progressive Scan High-Speed Shutter Camera

## Applications

- Motion analysis
- High-speed on-line inspection
- Gauging
- Character reading
- High definition graphics
- Fast speed surveillance

## General Description - REVISED

The PULNiX TM-6710CL is a high-resolution monochrome camera with non-interlace quad speed scanning, 120 Hz format and partial scanning (200 and 100 lines) capabilities.

The signal is analog progressive scanning (484 lines). The full frame electronic shutter with asynchronous reset permits shutter speeds to 1/32,000 sec. The shutter function works in all scanning modes. Square pixels provide excellent image definition in all orientations.

Optional features include AGC enable, internal IR cut filter, gamma adjust to 0.45, and remoted imagers.

## Camera Link

Camera Link is a digital transmission standard developed through an initiative headed by PULNiX America, specifically for the machine vision industry in answer to customer requests. This specification includes data transmission as well as camera control and asynchronous serial communications, all on a single cable. Based on an implementation of National Semiconductor's Channel Link technology, it defines a single connector for both frame grabbers and cameras, ensuring that all products bearing the Camera Link logo are interchangeable with each other.

## Integration

The CCD imager of the TM-6710CL can be exposed longer than normal TV timing (1/60 sec.). This feature provides high sensitivity for dark-environment applications. Integration is achieved by controlling the pulse width of VINIT input up to a few seconds. The progressive scanning CCD chip in the TM-6710CL produces a full frame of resolution, using a frame grabber to capture the one frame of integrated image in non-interlace format.



## Product Features

- High resolution 1/2" progressive scanning interline transfer CCD imager 648(H) x 484(V)
- Quad speed progressive scan - 120 Hz at full resolution or (partial scan at up to 300 Hz)
- 120 Hz, 60 Hz switchable
- Full frame shutter, 1/60 to 1/32,000 sec.
- Asynchronous reset with external shutter control
- 8-bit x 2 (or 8-bit x 1) digital Camera Link output
- Software Control via Camera Link interface for gain, A/D ref., shutter and mode selection (compatible with Win98/NT/2000/XP OS)
- AGC on/off, gamma 1.0 or 0.45 (AGC off, gamma 1.0 standard)
- On chip micro-lens and low smear at fast shutter

## Asynchronous Reset

The TM-6710CL's asynchronous reset is flexible and takes external horizontal drive (HD) for phase locking (External HD = Analog HD Output/2). When VINIT pulse is applied, it resets the camera's scanning and purges the CCD.

Three modes control the asynchronous reset and shutter speed. With Async shutter mode and external VINIT high (5V), the async mode is automatically selected and the signal readout is inhibited until the trigger pulse occurs. Without VINIT trigger, the output is black video.

1. External VINIT with controlled pulse width. The duration between pulse edges (5 volt TTL level) controls the shutter speed and integration period externally.
2. Internal shutter speed with Fast mode. The video signal capturing has no delay from the reset timing if the falling edges of VINIT and external HD are the same. Otherwise, there is maximum HD delay before vertical scan resets.
3. Internal shutter speed with Slow mode. The shutter speed control can be selected from 1/250 to 1/2,000 sec. Since the exposure period is longer than the frame period, the data transfer is delayed to accommodate exposure.

## Electronic Shutter

The TM-6710CL has a substrate drain-type shutter mechanism which produces a superb picture at various speeds without smearing. The built-in manual shutter speed control selects the electronic shutter rate of 1/250, 1/500, 1/1,000, 1/2,000, 1/4,000, 1/8,000, 1/16,000, or 1/32,000 sec. All shutter speeds are applied to partial scan, except slow speed at partial scanning. Progressive scanning allows a full 484 lines of vertical resolution per single shutter, unlike a conventional CCD camera at only 244 lines per shutter.

## Partial Scanning - REVISED

By using the GUI or sending the RS-232 command, the TM-6710CL can have partial scanning of 200 and 100 lines (full resolution at narrower field of view and faster frame rate).

Normal mode:	120 Hz/60 Hz progressive scan
200 line scan:	236 Hz progressive scan
100 line scan:	300 Hz progressive scan

Normal mode: 120 Hz or 60 Hz is selectable from software control. At 60 Hz all parameters extend to half speed. See frame rate - FAST: 120Hz HALF: 60Hz.

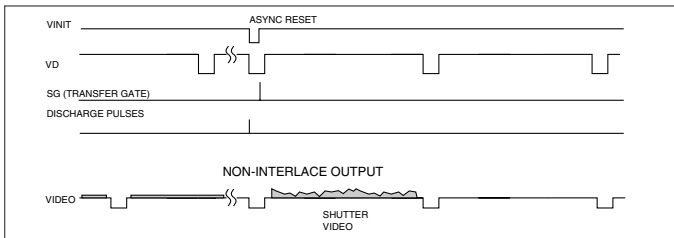

Shutter Control \*

	Manual Shutter		Async Reset	
0	no shutter	1/120	normal	1/120
1	1/250	128H	1H	1/32,000
2	1/500	64H	2H	1/16,000
3	1/1,000	32H	3H	1/12,000
4	1/2,000	16H	4H	1/8,000
5	1/4,000	8H	8H	1/4,000
6	1/8,000	4H	16H	1/2,000
7	1/12,000	3H	32H	1/1,000
8	1/16,000	2H	64H	1/500
9	1/32,000	1H	Shutter determined by pulse width (P.W.C.)	

\* All shutter timing refers to 120fps full resolution 640 x 480 mode output.

### Async Reset Mode:

- Mode 0: normal mode;
- Mode 1-4: fast mode;
- Mode 5-8: slow mode;
- Mode 9: pulse width mode.

At modes 1-9 the camera is at standby only, black video is output. One frame image will be output upon receiving an async reset pulse.

## Mode Control Software - REVISED

User-friendly GUI software, p/n 69-0062, is provided for Mode Switch control. This interface allows users to control the following functions of the TM-670CL camera:

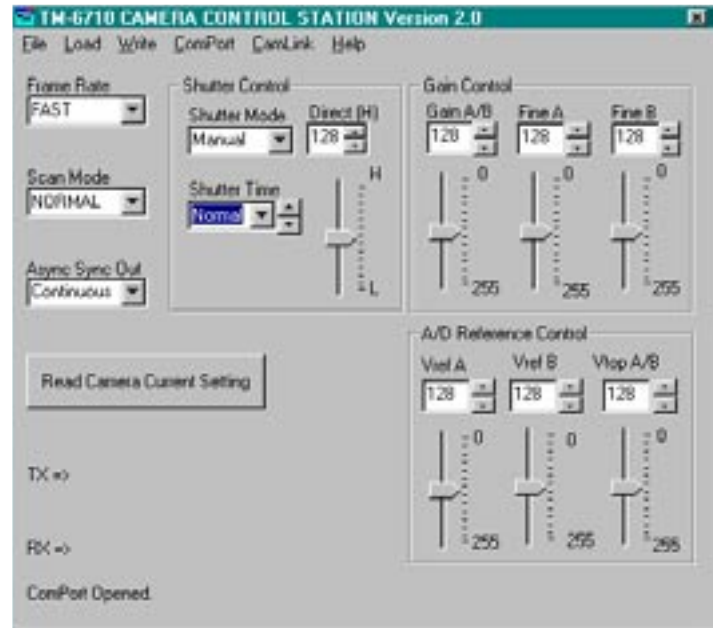

- Gain control - increase/decrease gain of Ch. A & Ch. B
- Gain fine tune - increase/decrease gain of Ch. A, while decrease/increase Ch. B at 5:1 ratio
- Ch. A Vref control - increase/decrease A/D voltage reference
- Ch. B Vref control - increase/decrease A/D voltage reference
- Gain selection - 9dB to 22dB
- Clock selection - 60Hz (input sync changed automatically) to 120Hz
- Async/Manual Shutter control
- Factory set recall
- Power up (recall or save)
- User page storage
- Direct Shutter - increase/decrease manual shutter speed
- Partial scan rate - choice of 200 lines, 100 lines

Camera parameters can be uploaded from the PC to the camera. Once these parameters are stored in EEPROMs, an instantaneous change from one setting to another can be done with a delay of few frames in between.

## Analog Video

Analog video output is available from the #4 pin of the 12-pin connector. This output is a single output that combines channels A and B, which means the horizontal speed is twice as fast as each individual digital output (fH = 60.98 kHz). The signal level is similar to RS-170 (1.0V p-p at 75 Ω).

## External Synchronization

The TM-6710CL can accept external HD and VD for phase locking. The internal PLL can accept external HD and lock with the CCD's horizontal drive (HD). The CCD HD frequency is half of the analog video output HD.

Example: Ext. HD = 30.49 kHz; VD will be 120 Hz and Master Clock will be 50.90 MHz.

The internal sync generator can accept external VD to generate internal VD. The external VD frequency should be  $\pm 5\%$  of the frame rate.

The external sync is TTL level and applied to the 12-pin connector.

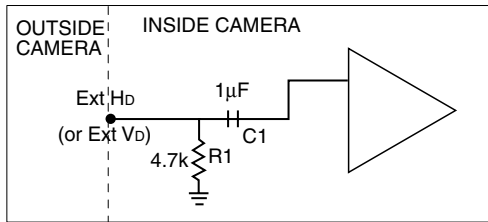

External Sync Input Schematic  

$$\text{Ext. HD} = \frac{\text{Analog Output Frequency}}{\text{Frequency} \times 2}$$

## Dual-Tap Video Output

The TM-6710CL uses a dual-tap output for its fast frame readout.

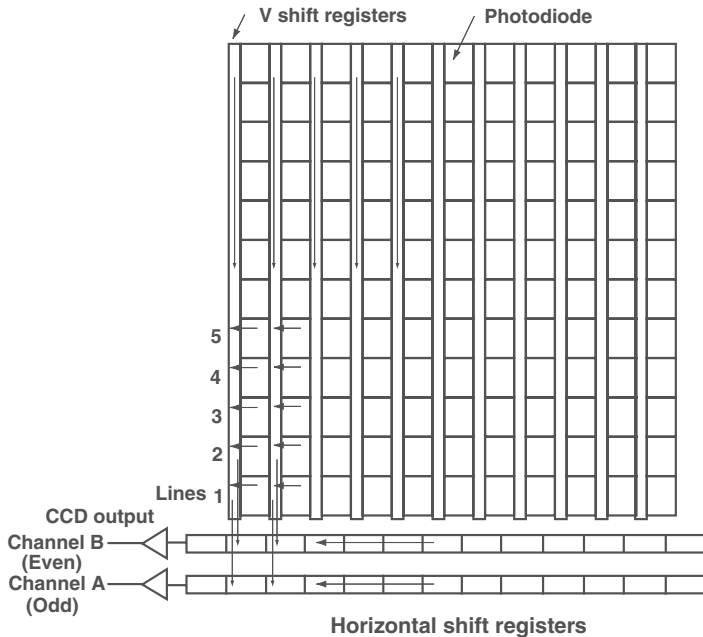

At the same horizontal clock cycle, line 1 and odd lines go to channel A, line 2 and even lines go to channel B. Vertical shift registers move twice per horizontal blanking period. Lines 1 and 2, 3 and 4, and so on, are output from channel A and B simultaneously.

## Connector and Pin Configurations

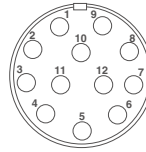

### 12-Pin Connector

1	GND (power)	7	VD in
2	+12V	8	N/C
3	GND (analog)	9	HD in
4	Video out	10	RXD*
5	GND (digital)	11	INTEG
6	VINIT in	12	TXD*

\* Optional TTL serial communications

### Camera Link Connector

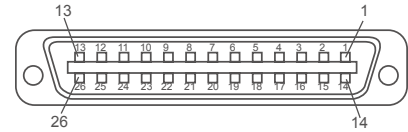

### MDR 26-Pin Connector (0226-622VC)

Pin#	Description	Pin#	Description
1	GND (Shield)	14	GND (Shield)
2	X0-	15	X0+
3	X1-	16	X1+
4	X2-	17	X2+
5	Xclk-	18	Xclk+
6	X3-	19	X3+
7	SerTC+	20	SerTC-
8	SerTFG-	21	SerTFG+
9	VINIT (CC1-)	22	VINIT (CC1+)
10	INTEG (CC2-)	23	INTEG (CC2+)
11	CC3-	24	CC3+
12	CC4+	25	CC4-
13	GND (Shield)	26	GND (Shield)

### Camera Link Signal Assignment to Channel Link Chip (Base Configuration)

Tx IN0	Data A0 (LSB)
Tx IN1	Data A1
Tx IN2	Data A2
Tx IN3	Data A3
Tx IN4	Data A4
Tx IN5	Data A7 (MSB)
Tx IN6	Data A5
Tx IN7	Data B0
Tx IN8	Data B1
Tx IN9	Data B2
Tx IN10	Data B6
Tx IN11	Data B7
Tx IN12	Data B3
Tx IN13	Data B4
Tx IN14	Data B5
(TxIN15 thru 22 Reserved)	
Tx IN23	
Tx IN24	LDV
Tx IN25	FDV
Tx IN26	Reserved
Tx IN27	Data A6

Data A represents Odd lines (channel A)  
 Data B represents Even lines (channel B)

## SPECIFICATIONS - REVISED

Imager	1/2" progressive scan interline transfer CCD
Active Area	5.8mm x 4.3mm
Active Pixel	648 (H) x 484 (V)
Cell Size	9.0 μm x 9.0 μm
Scan Modes (Active Pixels)	648 (H) x 484 (V) @ 120 Hz/60 Hz 648 (H) x 200 lines @ 236 Hz 648 (H) x 100 lines @ 300 Hz
Sync	HD= 30.49KHz ±5% (at 50.980MHz) Vertical async. reset. or VD=120Hz±5% HD=23.97KHz±5% (at 40.00MHz - optional) Vertical async. reset. or VD=96Hz±5% (opt.)
Data Clock Output	25.49 MHz (50.98MHz analog) or 20.03 MHz (40.06MHz analog)
TV Resolution	Analog: 500 pixels (H) x 484 lines (V)
S/N Ratio	45dB min. (AGC = off)
Min. Illumination	4 lux at normal speed (120 frame/sec)
Video Output	Analog: 1.0 Vp-p composite , 75Ω non-interlace Digital: Camera Link

AGC	OFF (AGC ON is a factory option)
Gamma	1.0 (Gamma 0.45 is a factory option)
Lens Mount	C-mount
Power Req.	12V DC, 700 mA
Operating Temp.	-10 °C to 50 °C
Vibration	7 Grms (10Hz x 2000Hz)
Shock	70G
Size (W x H x L)	46.1mm x 39.6mm x 140.0mm (1.81" x 1.56" x 5.51")
Weight	260 gr (9.2 oz)

MUST BE ORDERED SEPARATELY	
Optional Functions	AGC ON, Gamma 0.45
Optional Accessories	
Power Cable	12P-02S
Power Supply	PD-12UUP series
Camera Link Cable	26CL-02-26

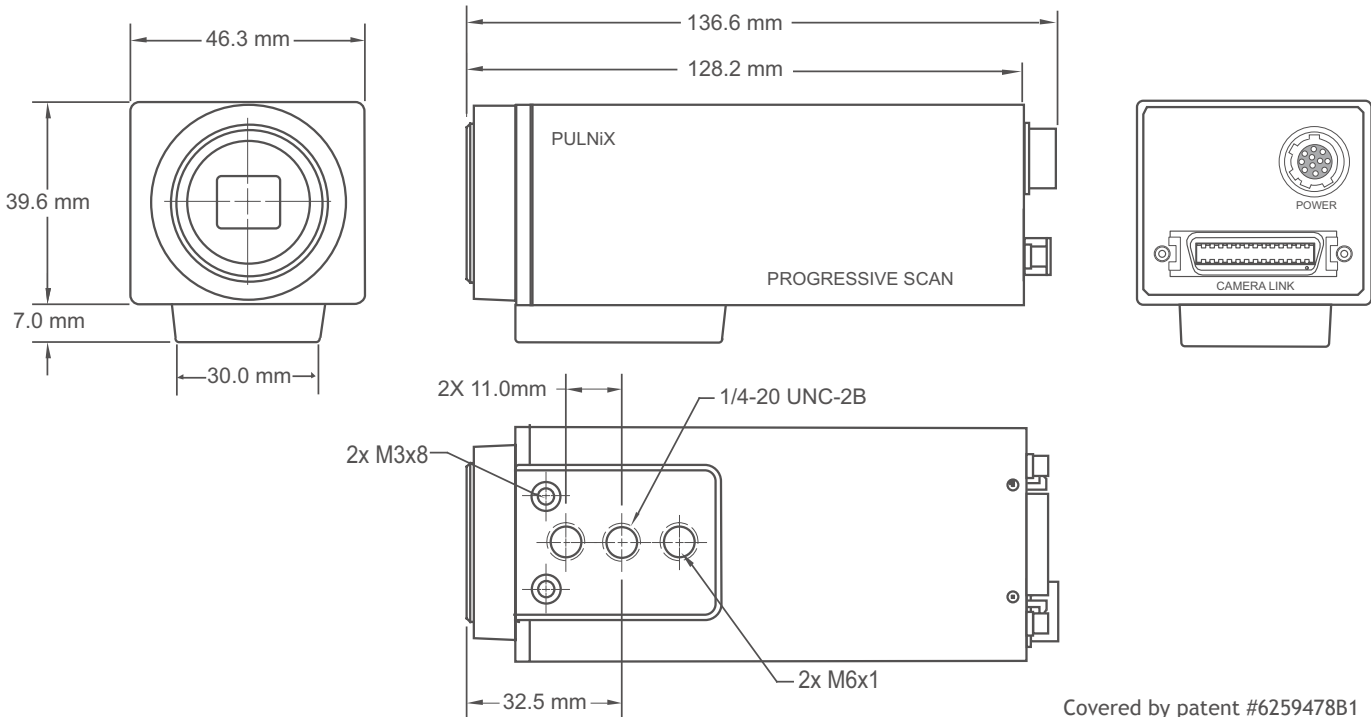

Covered by patent #6259478B1

JAI A-S, Denmark  
Phone +45 4457 8888  
www.jai.com

JAI UK Ltd., England  
Phone: +44 189 582 1481  
www.jai.com

JAI Corporation, Japan  
Phone: +81 045 440 0154  
www.jai-corp.co.jp

JAI PULNiX, Germany  
Phone +49-(0) 60 55-93 79-10  
www.jaipulnix.com

JAI PULNiX Inc., USA  
1330 Orleans Drive  
Sunnyvale  
CA 94089  
USA

Phone +1 408-747-0300  
(toll-free) 1 800 445 5444  
Fax +1 408 747 0660  
www.jaipulnix.com

**jai**<sup>®</sup>  
**PULNiX**  
www.jaipulnix.com