



General Description

The TMC-7DSP/TMC-6DSP offers PULNiX's state of the art proprietary high performance Digital Signal Processing (DSP) in a high resolution 1/2" CCD format. This versatile camera outputs VBS (NTSC or PAL), Y/C or S-Video, and RGB. With TTL (through-the-lens) auto/manual white balance, these cameras are particularly easy to use. Low light sensitivity is 2 lux at F1.4. The capability to vary the electronic shutter rate externally is a standard feature. The TMC-7DSP/ TMC-6DSP accepts external HD-Vd or composite sync.

The popular standard or mini-cylindrical remote head configurations (one meter separation) are optional for all models. Custom remote imager lengths are available by special order.

Applications

Rugged construction, superb color reproduction and high resistance to vibration and shock make these cameras ideal for both industrial and CCTV surveillance applications. Suggested applications include:

- Teleconferencing
- Machine vision
- Object recognition
- Medical systems
- Process monitoring
- Airborne imaging
- Remote observation

Electronic Shutter

The TMC-7DSP/TMC-6DSP camera has a substrate drain type shutter mechanism, which vertically moves the charges in all the cells simultaneously. The result is a superb picture at various speeds without smearing.

The auto shutter function on the TMC-7DSP/ TMC-6DSP operates at high speed variable shutter (1/60 sec. to 1/10,000 sec.), adjusting the shutter speed automatically to maintain a wide dynamic range of video output (5 lux to 50,000 lux). Electronic shuttering eliminates the need for costly and distracting strobe lights on high speed assembly or inspection lines.

By selecting the internal jumper and mode selection switch, Auto Shutter (electronic iris control) is available. See Mode Selection pg. 3

Product Features

- High performance Digital Signal Processing (DSP)
- 768 (H) x 494 (V) resolution (460 horizontal TV lines)
- High sensitivity complementary color filter
- NTSC (TMC-7DSP) or PAL (TMC-6DSP), Y/C (S-Video), and RGB output (TMC-7DSP only)
- 1/60 to 1/10,000 sec. programmable shutter, and auto shutter
- Wide dynamic range and excellent S/N ratio
- RS-232C external control for gain, white balance, and other functions
- External sync (HD, VD sync) capability

Complementary Color Filter

The high sensitivity complementary color filter uses complementary stripe color filters of Cy, Gr and Ye. More sensitive than R, G, B primary color systems, a broader range of color variations are generated for outstanding color fidelity

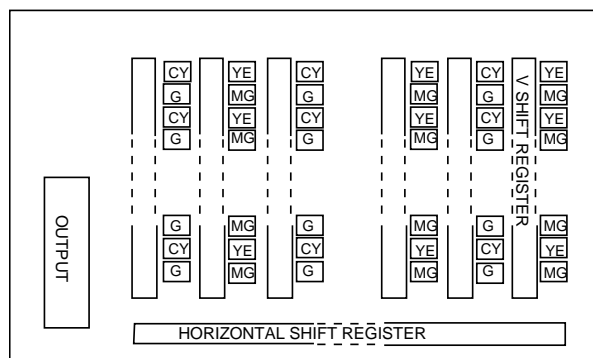

Complementary Mosaic Filter

Shutter Mode Switch

Switch Setting	TMC-7DSP (NTSC)	TMC-6DSP (PAL)
0	1/60sec.	1/50sec.
1	1/100	1/120
2	1/250	1/250
3	1/500	1/500
4	1/1,000	1/1,000
5	1/2,000	1/2,000
6	1/4,000	1/4,000
7	1/10,000	1/10,000
8	(not used)	
9	(not used)	

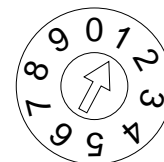

TMC-7DSP/TMC-6DSP

RGB Output

The TMC-7DSP color camera can output RGB signals without the use of a "Breakout" module. The TMC-7DSP camera outputs separate RGB and sync signals directly out of the camera via the same 12-pin connector that is used for power and sync signals.

Note: RGB output is only available on the NTSC version (TMC-7DSP).

Y/C Output

Y/C output is available via a 6-pin connector. The Y signal can also be used for auto iris control.

Spectral Response

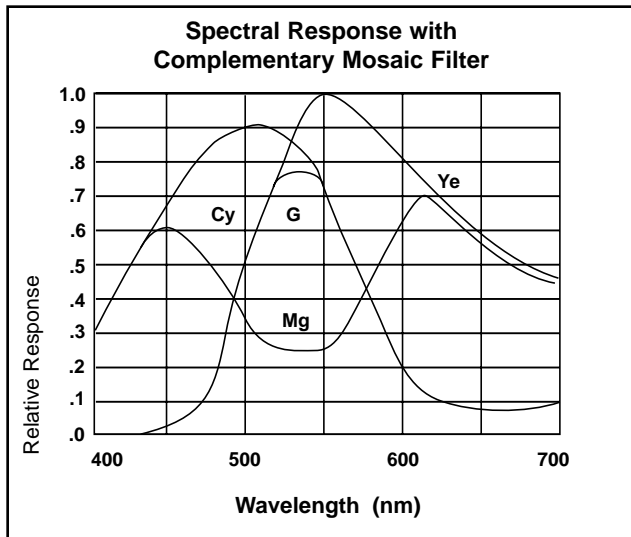

Pin Configurations

Camera Rear Panel 12-Pin Connector (PULNiX Part Number PC-12P. Used on all PULNiX Power Cables)

PIN#	DESCRIPTION
1	GND
2	+12V in
3	GND
4	Video out (VBS)
5	GND
6	Sync out
7	Ex VD
8	GND
9	Ex HD
10	R out
11	G out
12	B out

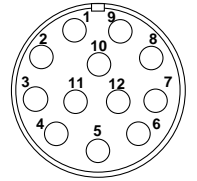

Camera Rear Panel 6-Pin Connector (PULNiX Part Number PC-6P)

PIN#	DESCRIPTION
1	RS-232 RX
2	RS-232 TX
3	N/C (+12V out option)*
4	Y (Luminance)
5	C (Chrominance)
6	GND

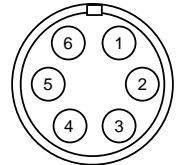

* For Pin #3, 12VDC is optional for auto iris control.

Software Control Features

- Shutter control AE/Manual
- White Balance Internal Auto/Hold/Ext
- Y Gain
- Gamma
- Back Light Compensation
- Pedestal
- Aperture
- Hue Control (RYgain, BYgain, RYhue, BYhue)
- Save / Load setting to / from hard disk
- Save / Load setting to / from EEPROM
- Report setting saved in EEPROM or hard disk

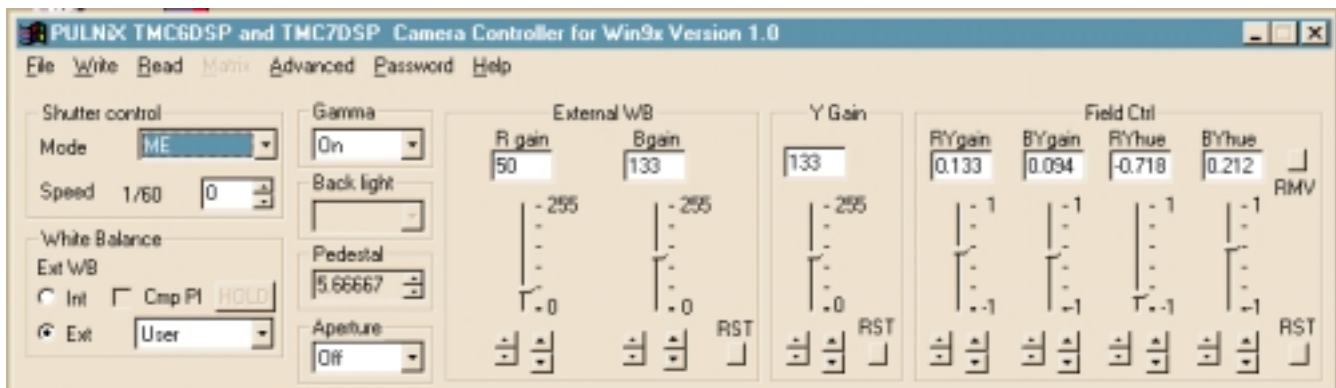

Modes

The seven white balance modes can be selected by switching SW1, SW2 and SW3 using the DIP switch.

Mode	SW1	SW2	SW3	Set color temp. (K)
ATW	UP(0)	UP(0)	UP(0)	
Push lock	UP(0)	DN(1)	UP(0)	
Hold	DN(1)	DN(1)	UP(0)	
Indoor Fixed Value	UP(0)	UP(0)	DN(1)	approx. 3200
Fluorescent light fixed value	DN(1)	UP(0)	DN(1)	approx. 4200
User (fl. light fixed value 2)	UP(0)	DN(1)	DN(1)	approx. 4700
Outdoor fixed value	DN(1)	DN(1)	DN(1)	approx. 6300

ATW

The Auto Trace White balance mode (ATW) is a feedback system that automatically aligns the white balance by detecting the R-G and B-G before gamma correction processing.

Push Lock

Convergence is performed at a faster operating speed than ATW without an operation frame or other limitations. However, the response time, operation frame and other factors cannot be selected.

Hold

When shifting to the Hold mode, the convergence operation is stopped and the R, G and B gains at that point are written to the EEPROM. Push Lock mode and Hold mode can be combined to realize Push Lock mode. Operation is performed in Push Lock mode while the button is pressed and shifts to Hold mode when the button is released, allowing the white balance gain at that point to be written to the EEPROM.

AE

SW4	AE/ME	UP (L) AE Mode		DOWN ME Mode
JSW1	FLON	Close (L) Flickerless OFF	Open (H) *1 Flickerless ON	JSW1-4 are not active in ME mode
JSW2	BLCOF	Close (L) Background lighting correction ON	Open (H) Background lighting Correction OFF	
JSW3	MIRIS	Close (L) Electronic iris	Open (H) Mechanical iris	
JSW4	AEREF	Close (L) 1001RE setting	Open (H) User setting values	
JSW5	AGCMAX	Close (L) 20dBmax	Open (H) 26dBmax	

*1. NTSC : 1/100s; PAL : 1/120s

Note: For AE setting: AE/ME(UP), FLON(CLOSE), MIRIS(CLOSE)

Gamma Variant

JSW6	GAMMA	Close (L)	Open (H)
		Gamma 0.45 (typical)	Gamma 1.0 (linear)

Jumper Switch (JSW) *

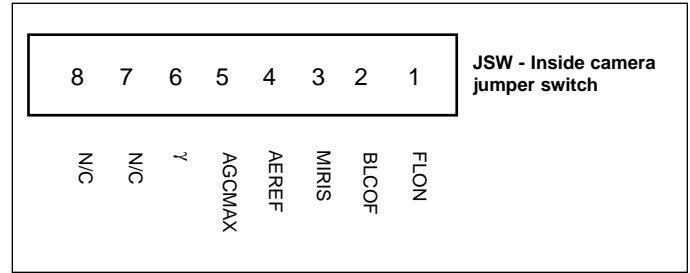

SWITCH

DESCRIPTION

AE/ME	Automatic exposure or manual exposure
FLON	Flickerless mode
BLCOF	Backlight compensation off
MIRIS	Iris mode switching
AEREF	AE convergence level switching
AGCMAX	AGC maximum gain switching
γ	Gamma correction ON/OFF

***NOTE:** This section is for information only. Removing the camera cover voids the PULNiX 3-year warranty. Contact PULNiX for further details.

Specifications

Model	TMC-7DSP (NTSC)	TMC-6DSP (PAL)
Imager	1/2" interline transfer CCD (6.4 x 4.8 mm)	
Pixel	768(H) x 494(V)	752(H) x 582(V)
Cell size	8.4µm(H) x 9.8µm(V)	8.6µm(H) x 8.3µm(V)
Color filter	Cy, Ye, Mg, G complementary color filter	
Scanning	2:1 interlace, field mode scanning	
Sync	525 lines, 59.94 Hz	625 lines, 50 Hz
TV resolution	Internal sync; internal sync/external auto switch with HD/VD-input	
S/N ratio	fH = 15.734 KHz fV = 59.94 Hz	fH = 15.625 KHz fV = 50.00 Hz
Min. illumination	460(H) x 400(V) TV lines	450(H) x 450(V) TV lines
Video output	50 dB (AGC off) 2 Lux F = 1.4 (AGC on) VBS = 1.0 Vp-p at 75 Ω (NTSC and PAL) Y (B/W) = 1.0 Vp-p with sync, Chroma = 285 mV at 75 Ω (Y/C or S-VHS) RGB = 714m Vp-p without sync, Sync 285mV at 75Ω (TMC-7DSP only)	
Color balance	Through-the-lens auto white balance: memory (std) or auto-tracking (option) and manual hue adjustment	
AGC	Max. 32 dB AGC, on-off switchable, manual gain control	
Gamma	0.45 (factory standard); 1:0 (programmable)	
Lens mount	C-mount	
Power req.	12V DC, 280 mA	
Operating temp.	-10°C to +50°C	
Vibration & shock	Vibration: 7 Grms 10Hz to 2000Hz), Shock: 70 G	
Size (W x H x L)	42mm x 32mm x 146mm (1.65" x 1.26" x 5.74")	
Weight	210 grams (7.3 oz)	
Power cable	12P-02, external sync	
Power supply	external sync 12VDC, 500mA	
External control	Manual shutter speed, AWB mode and RS-232C (see pg. 2 for details)	
Functional options	Refer to Option/Matrix chart on current price list	
Accessories	CS-232-7D (Y/C and RS-232 Controller Set), CBL-2R-7D RGB cable (TMC-7DSP only), RS-232C-9 (RS-232 cable)	

Due to ongoing product improvements, specifications may change without notice.

Dimensions

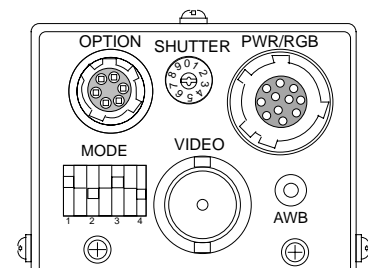
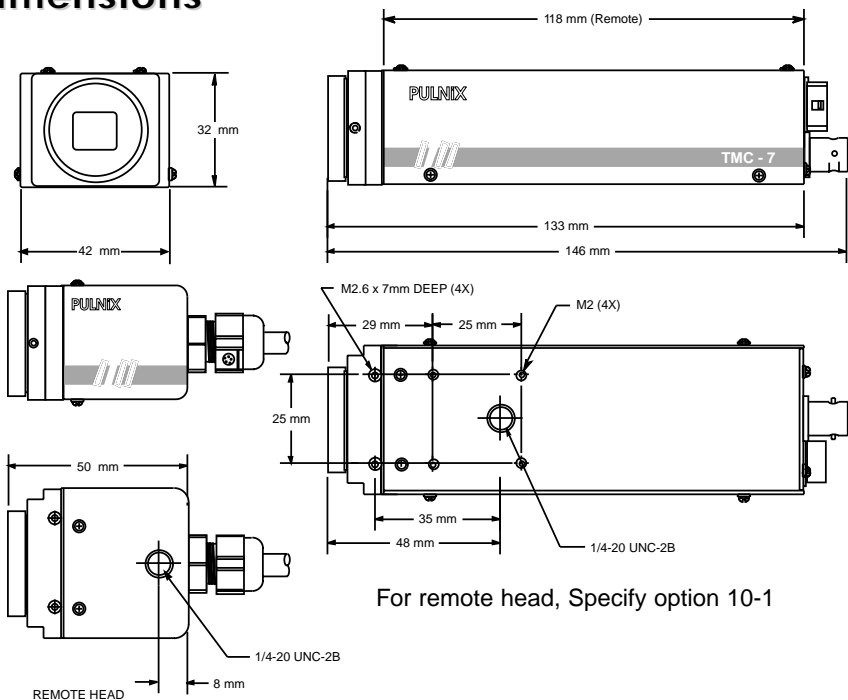

Rear panel

CE Compliance

All PULNiX products bearing the "CE" mark have been certified for CE compliance. Please note that the use of non-shielded or improperly shielded interconnect cables may effect CE compliance. Please contact the PULNiX Sales Applications Engineering department for further information specific to CE compliance.

Japan
PULNiX America, Inc.
Ogura Building, 1-11-14
Hongo
Bunkyo-ku, Tokyo 113-0033
Tel: 81-3-5805-2455
Fax: 81-3-5805-8082
Kyoto Office
Tel: 81-75-592-2247
Fax: 81-75-591-2333

Australia
PULNiX America, Inc.
Unit 16, #35 Garden Road
Clayton, Vic 3168
Tel: 61-3-9546-0222
Fax: 61-3-9562-4892

United Kingdom
PULNiX Europe, Ltd.
Aviary Court, Wade Road
Basingstoke, Hampshire RG24
8PE
Tel: 44-1256-475555
Fax: 44-1256-466268

Germany
PULNiX America, Inc.
Siemensstrasse 12
D-63755 Alzenau
Germany
Tel: 49(0)6023-9625-0
Fax: 49(0)6023-9625-11

ISO-9001
Cert. #A3942 rvc



PULNiX
Industrial Products Division

PULNiX America, Inc. Tel: 408-747-0300
1330 Orleans Drive Tel: 800-445-5444
Sunnyvale, CA 94089 Fax: 408-747-0660
Email: pulnix@pulnix.com
www.pulnix.com

TM-7DSP/TMC-6DSP

71-0037 Rev. A
Printed: 2/00