



Product Features

- RGB primary color 2/3" progressive scanning interline transfer CCD imager 768(H) x 484(V)
- Full digital processing using real time DSPs
- Progressive scan (525 lines) and interlace scan (RS-170) output in 24-bit digital, RGB analog, NTSC and optional Y/C format
- Full frame shutter, 1/60 to 1/16,000 sec.
- Asynchronous reset with continuous video out
- Frame memory built-in for async and integration image capturing
- Full frame integration with uninterrupted video
- RS-232C external control for CPU and DSP

General Description

The PULNiX TMC-9700 is a high resolution progressive scan color camera with asynchronous reset capability and continuous video output. The primary-color, 3G/R/B staggered progressive scan interline transfer CCD combines excellent resolution and color fidelity with superb electronic shutter capability. Progressive scanning permits a full frame of image resolution per shutter or integration, a significant advantage over TV format (interlace) color cameras including 3-chip CCD cameras. The TMC-9700 has a built-in frame memory for async or integration image capturing, therefore eliminating the need for special async frame grabbers.

The TMC-9700 is designed to output both progressive scan and standard continuous interlace video simultaneously so that ordinary video equipment can display and process the asynchronous images. The digital output signal is interlace (RS-170) or progressive scan (525 lines). Added to the versatility of this camera is a 24-bit, buffered TTL digital signal output (RS-422 converter module is optional).

The built-in Central Processing Unit (CPU) and Digital Signal Processor (DSP) are controlled by an RS-232C communication port as well as programming switches on the rear panel, for color matrix, white balance, gain, edge enhance, scanning mode and other functions. The functions selected are saved to EEPROM to provide a consistent output in various applications.

The TMC-9700 is excellent in applications such as dynamic motion capturing, still picture storage, on-line inspection, gauging, printing, high definition graphics and high resolution surveillance.

Progressive Scan Interline Transfer CCD Color Filter

The TMC-9700 employs a unique color filter array (CFA) to obtain the best color fidelity and the maximum resolution from a single chip CCD structure. The CFA, called a "3G/R/B staggered CFA", comprises a ratio of three green pixels to one red or blue pixel. Since the human eye's resolution depends mostly on the green spectrum, this configuration is the best for a single chip CFA. Considered difficult to achieve, this color interpolation only can be implemented by digital signal processing technology. PULNiX has successfully developed the method to process such CFA interpolation with real time DSPs.

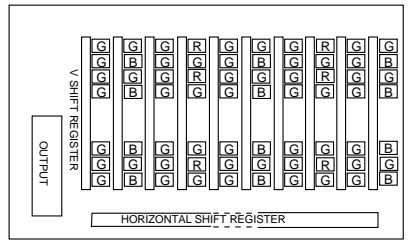

All signal processing is controlled by digital calculation. The color matrix generates a high level of color consistency for the most demanding industrial applications. The color matrix coefficients are externally controllable via the RS-232C communication port. PULNiX offers the user a simple software package for basic function control. There are four preset standard matrices available for easy selection:

- A: Improved matrix.....For higher chrominance
- B: 2X matrix.....Two times illuminance
- C: Unity matrix.....Normalized matrix
- D: Factory set matrix...DSP default matrix

TMC-9700

Asynchronous Reset

The TMC-9700's asynchronous reset operates with internal sync or external HD for phase locking. When VINIT pulse is applied, it resets the camera's scanning and purges the CCD. There are three modes to control the asynchronous reset and shutter speed:

- 1. External VINIT with pulse width control.** The pulse width between two pulse edges controls the shutter speed externally from 1/16,000 sec to 4 sec.
- 2. Internal shutter speed with Fast mode.** The video signal has no delay from the reset timing (shutter speed range is 1/2,000 to 1/16,000 sec.)
- 3. Internal shutter speed with Slow mode.** The speed control is variable from 1/125 to 1/1,000 sec. The video signal starts with internal V reset timing related to shutter speed.

The built-in frame memory maintains the asynchronously captured full frame image until the next VINIT pulse comes in. The output is either interlace or progressive scanning. Both analog RGB, NTSC format (1Vp-p, 75Ω) and 24-bit digital format (TTL) are available from the camera. The TMC-9700 has two sync generators, one for async image capturing and one for synchronous output for external interface.

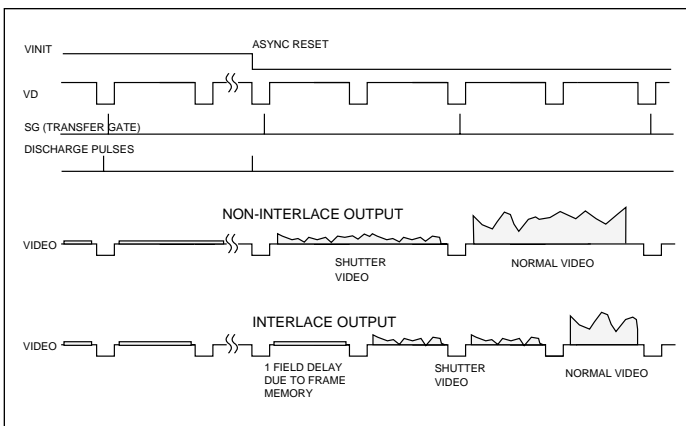

Integration

The CCD imager of the TMC-9700 can be exposed for longer than normal TV timing (integration, 1/30 sec.). This feature provides high sensitivity for low light applications. Integration is achieved by controlling the #11 pin of the 12-pin connector to Low (GND). Integration also can be achieved by VINIT pulse width control of the async shutter up to four seconds. The progressive scanning CCD chip permits a full frame of resolution to be obtained with either interlace or progressive scan format. The internal frame memory provides continuous video output.

Electronic Shutter

The TMC-9700 has a substrate drain type shutter mechanism which provides a superb picture at various speeds without smearing. Progressive scanning permits a full 484 lines of full vertical resolution per single shutter, compared with a normal CCD camera at only 244 lines per shutter. The manual shutter speed control selects the electronic shutter rate of 1/60, 1/125, 1/250, 1/500, 1/1,000, 1/2,000, 1/4,000, 1/8,000, or 1/16,000 sec.

Shutter Control Switch

	Manual	Async	
0	no shutter	no shutter	
1	1/60	1/16,000	
2	1/125	1/8,000	
3	1/250	1/4,000	
4	1/500	1/2,000	
5	1/1,000	1/1,000	
6	1/2,000	1/500	
7	1/4,000	1/250	
8	1/8,000	1/125	
9	1/16,000	Pulse width control	

The asynchronous shutter is activated by selecting async reset and the shutter speed. The async reset pulse, VINIT, must be applied to create the shutter. With VINIT high (5V), the CCD keeps discharging. With a negative going pulse to VINIT, the camera resets and purges the charge momentarily. Then it starts integrating for the period of shutter control set by either internal shutter control or external pulse width control. When "0" shutter is selected in async mode, the camera resets asynchronously without shutter function so that this mode can be used for strobe lighting applications.

Scan Conversion

The TMC-9700 has a built-in scan conversion circuit. Image capturing is always progressive scanning at 30 frames/sec. This means that the input is full-frame resolution regardless of electronic shutter, integration, or normal scanning. In order to interface with conventional video equipment, the progressive scan is converted to interlaced analog or digital output. Since the TMC-9700 has two sync generators, the output side is uninterrupted continuous video while the input side is random async process. This feature eliminates the need for special async frame grabbers.

The analog output is converted into three formats: RGB output, NTSC output and Y/C (S-VHS optional) output. The RGB and NTSC are available with a standard 9-pin connector cable (#50-1050). Y/C is due to the different cable pin out. The digital output is 8-bit x 3 (TTL). The internal A/D and DSP is 10-bit processing. The digital output for interlace and progressive scan is the same mode as the analog output.

For RS-422 interface, a CV100 RS-422 interface module is available (see page 4). It receives the standard 37-pin signal from the 30DG-02 cable and outputs a 24-bit RS-422 color signal from the 62-pin HDsub connector.

Mode Selection

Mode 0: Auto-white balance is saved as long as the power is on.

Mode Control Switch

Mode	Function
0	Auto W/B Reset
1	Manual Blue Adj.
2	Manual Red Adj.
3	LUT gain Adj.
4	Matrix Adj.
5	Sharpness On/Off
6	Shutter Int./Ext.
7	Sync Interlace/Progr.
8	Gamma 0.45/1.0
9	EEPROM Set
A	Page A Write/Read
B	Page B Write/Read
C	Page C Write/Read
D	Page D Write/Read
E	Page E Write/Read
F	Page F Write/Read

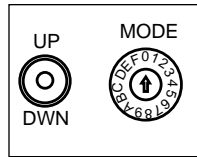

The camera mode selection is controlled by a rear panel mode switch. First select the mode, then press the up/down momentary switch to change or select the parameters.

Mode 1 - 3: External white balance varies with each color gain of log(B-G) and log(R-G). Mode 3 is the overall gain which changes all three factors in proportion to the setting of Modes 1 and 2 (LUT gain change).

Mode 4: Color matrix selection is available in four preset values.

Mode 5: The DSP has a horizontal and vertical edge enhancing algorithm.

Mode 6: Shutter mode (internal or async) selection. The shutter speed is controlled by the shutter speed switch.

Mode 7: Video output scanning mode (interlace or progressive) selection.

Mode 8: Gamma correction (0.45 or 1.0) selection.

Mode 9: Selects the image freeze function as an option to real time video.

Mode A - D: User pages for saving data (write page) and loading the data (read page). Page A is a user default page into which the data is automatically loaded at camera power up.

An RS-232C communication will overwrite the rear panel setting when RS-232C is executed. In order to resume the rear panel control, disconnect the RS-232C and reset the power.

Pin Configuration

12-Pin Connector

1	GND	7	VD in
2	+12V	8	GND
3	N/C	9	HD in
4	N/C	10	GND
5	GND	11	Int cont
6	VINIT	12	GND

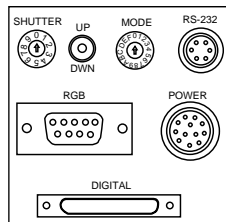

31-Pin Connector

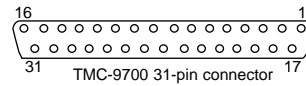

Pin #	Description	Pin#	Description
1	RED D0	17	RED D1
2	RED D2	18	RED D3
3	RED D4	19	RED D5
4	RED D6	20	REDD7
5	GRN D0	21	GRN D1
6	GRN D2	22	GRN D3
7	GRN D4	23	GRN D5
8	GRN D6	24	GRN D7
9	BLU D0	25	BLU D1
10	BLU D2	26	BLU D3
11	BLU D4	27	BLU D5
12	BLU D6	28	BLU D7
13	FDV	29	LDV
14	SYNC	30	CLK
15	BLANK	31	GND
16	GND		

Note: CLK: data clock (14.3 MHz)
LDV: Line data valid
FDV: Frame or field data valid

9-Pin RGB Connector

Pin#	Description
1	C (option)
2	GND
3	R OUT
4	G OUT
5	B OUT
6	NTSC OUT
7	SYNC WITH Y SIGNAL
8	GND
9	GND

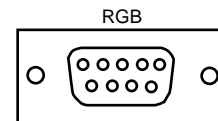

Compatible to TMC-54GN, XC-711. Use RGB cable assembly #50-1050. (Y/C option cable is not available)

RS-232 Connector (6-Pin)

RS-232	Description
1	RXD,
2	TXD,
3	RTS,
4 - 6	GND



RS-232C control software controls all the rear plate switch functions and DSPs. The DOS base software is operable from any IBM or clone PC's RS-232C with easy menu driven operation. The RS-232C is used as two way communication so that it not only controls functions but also reads the current setting parameters.

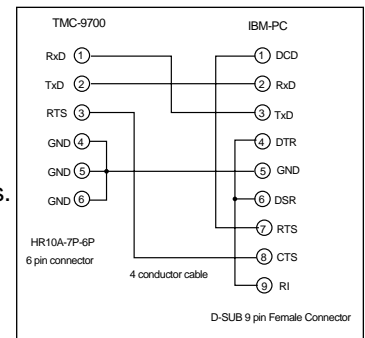

Specifications

Imager	2/3" progressive scanning interline transfer CCD (Primary RGB color filter)
Pixel	768 (H) x 484 (V)
Cell size	11.6 μm x 13.6 μm progressive scan
Scanning	Progressive, 525 lines 30 Hz or 60 Hz 2:1 interlace
Sync	Internal/external auto switch HD/VD, 4.0 Vp-p impedance 4.7K Ω VD=interlace 60 Hz/non-interlace 30 Hz HD=15.734kHz \pm 5%
Data clock output	14.31818 MHz
TV resolution	470 (H) x 484 (V) (analog), 760 x 484 (digital sampling)
S/N ratio	50dB
Min. illumination	10.0 lux, f=1.4 (no shutter). Sensitivity: 10 $\mu\text{V}/\text{e}$ -
Video output	1.0 Vp-p RGB and NTSC video, @75 Ω and 8-bit x 3 TTL output
AGC	OFF
Gamma	0.45 or 1.0 (0.45 std.)
Lens mount	C-mount
Power req.	12V DC 600 mA
Operating temp.	-10°C to 50°C
Vibration & shock	Vibration: 7G, Shock: 70G
Size (W x H x L)	51mm x 46mm x 162mm (2.00" x 1.81" x 6.38")
Weight	225 grams (4.3 oz)
Power cable	12P-02
Power supply	K25-12V, PD-12, or PD-12P (with 12 pin connector)
Auto iris connector	None
Functional options	Y/C output
Accessories	30DGC-02 digital cable, RGB cable, model CS-232 RS-232C cable with software set, CV-100 RS-422 module

CV-100 RS-422 Converter Module

Power req.	12V DC 600 mA
Size (W x H x L)	41.7mm x 76.2mm x 118mm 1.64" x 3.00" x 4.65"
Weight	229 grams (8.1 oz.)

CV-100 62-Pin Connector

Pin#	Description	Pin#	Description	Pin#	Description
1	BD3+	22	BD3-	43	BD4+
2	BD2+	23	BD2-	44	BD4-
3	BD1+	24	BD1-	45	BD5+
4	BD0+	25	BD0-	46	BD5-
5	GD7+	26	GD7-	47	BD6+
6	GD6+	27	GD6-	48	BD6-
7	GD5+	28	GD5-	49	BD7+
8	GD4+	29	GD4-	50	BD7-
9	GD3+	30	GD3-	51	FDV+
10	GD2+	31	GD2-	52	5DV-
11	GD1+	32	GD1-	53	SYNC+
12	GD0+	33	GD0-	54	SYNC-
13	RD7+	34	RD7-	55	BLNK+
14	RD6+	35	RD6-	56	BLNK-
15	RD5+	36	RD5-	57	LDV+
16	RD4+	37	RD4-	58	LDV-
17	RD3+	38	RD3-	59	CLK+
18	RD2+	39	RD2-	60	CLK-
19	RD1+	40	RD1-	61	GND
20	RD0+	41	RD0-	62	+5V IN
21	GND	42	N/C		

CV-100 37-Pin Connector

Pin#	Description	Pin#	Description	Pin#	Description
1	RD0	14	SYNC	27	GD7
2	RD2	15	BLNK	28	BD1
3	RD4	16	GND	29	BD3
4	RD6	17	GND	30	BD5
5	GD0	18	N/C	31	BD7
6	GD2	19	N/C	32	LDV
7	GD4	20	RD1	33	CLK
8	GD6	21	RD3	34	GND
9	BD0	22	RD5	35	GND
10	BD2	23	RD7	36	GND
11	BD4	24	GD1	37	GND
12	BD6	25	GD3		
13	FDV	26	GD5		

Power: Pin 1 +12 VDC, Pin 2 GND, Pin 3 N/C

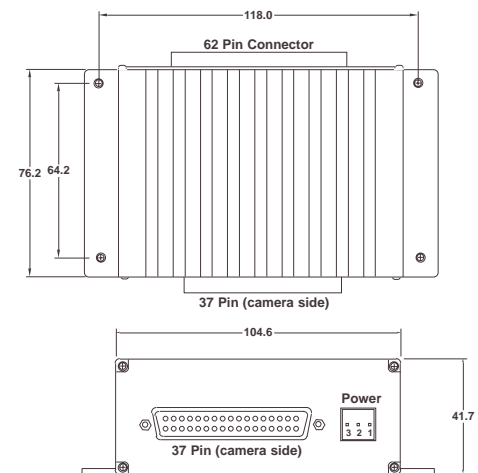

Dimensions (mm)

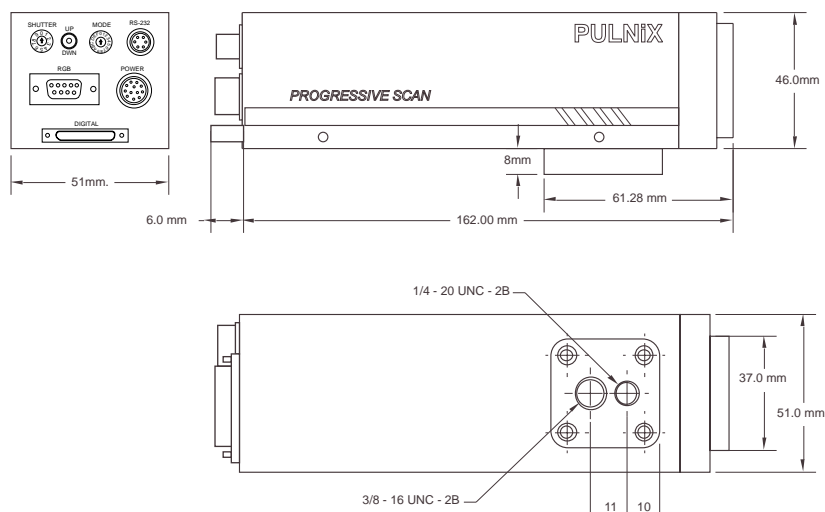

TMC-9700

TMC-9700/297
Printed: 07/99

ISO-9001
Cert. #A39



Industrial Products Division
PULNiX America Inc. Tel: 408-747-0300
 1330 Orleans Drive Tel: 800-445-5444
 Sunnyvale, CA 94089 Fax: 408-747-0660
 Email: imaging@pulnix.com
www.pulnix.com